

Flanging Tool Product Operating Manual

Nov 2007

Flanging Kit Part Names

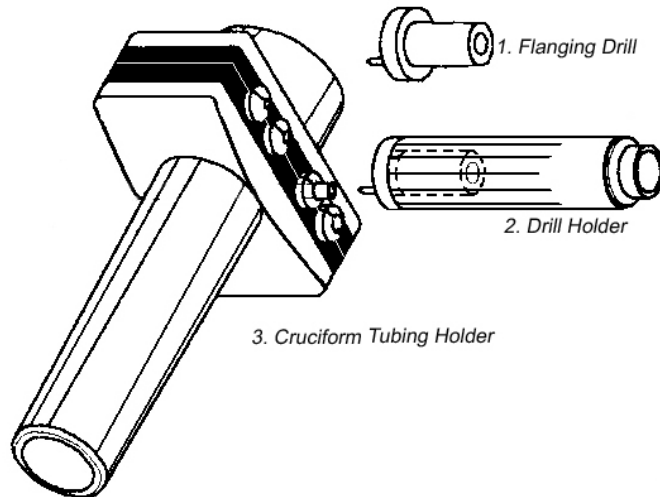

Figure 1

1. Getting Started: Insert Your Low Pressure Fittings.

Select a "Low Pressure Fitting" that is appropriate for the OD of the "Low Pressure Tubing" you want to flange. Place it over the tubing and slide it back approximately 10 inches over the tubing with the threads of the "Fitting" facing toward the opening of the tube. Next, slide the washer over the tubing so that it is between the Fitting and the Tube opening.

2. Insert Your Tubing into the Cruciform Tubing Holder (3).

Loosen the large knob on top of the Cruciform Tubing Holder (Figure 1, #3) by turning it counter clockwise until you can easily slide the tubing through one of the Holder's mid-section holes. Next, slowly begin to tighten the knob being very careful to maintain the proper position on the Holder and so that the tubing doesn't become kinked or loose. Do not fully tighten down the knob--just create a finger tight hold on the tubing.

3. Determine the length of the tubing to be flanged.

To create a proper flange it is necessary to determine the length of tubing that extends from the "Cruciform Tubing Holder" as in step 2 above. To do so use the side of the "Drill Holder" (Figure 2) opposite from where the Flanging Drills (1) are inserted. The tubing should be pushed back into the Cruciform Holder with the butt end of the Drill Holder until the Drill Holder is flush against the Cruciform Holder. Tighten down the knob on the top of the Cruciform Tubing Holder so that the tubing is held snugly. This is a very important step to insure that the flange is created properly. See Figure 3 (Red Tubing) below.

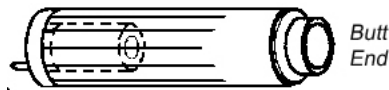

Figure 2

4. Choose the Right Flanging Drill (1).

Choose the Flanging Drill (red plastic head with metal drill bit) with the most appropriate OD drill bit for the size tubing you are using. Push the Flanging Drill into the Drill Holder (2) (white cylindrical handle) with the metal drill pointing away from the Drill Holder until you hear it "click". The Flanging Drill should be free to rotate inside the Drill Holder. Be careful not to bend the drill bit at any time.

5. Create the Flange.

As shown in Figure 3 below, with the proper amount of tubing extending out of the Cruciform Tubing Holder place the Drill Bit into the id of the tubing and rotate (clockwise or counter clockwise). While turning the Drill Holder keep it perpendicular to the Cruciform Tubing Holder. The Drill Holder will make larger rotations but the drill bit will not.

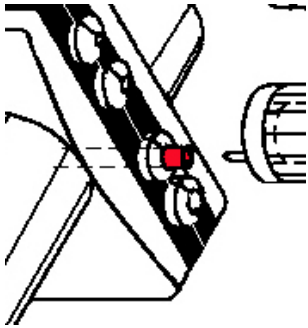

Figure 3

Without pushing too hard on the tubing spin the Drill Holder as shown in Figure 4 while applying increasing pressure between the Cruciform Tubing Holder and the Drill Holder or until the flange is appropriately sized.

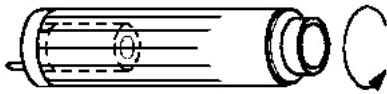

Figure 4

6. Remove Your Tubing.

Remove the tubing from cruciform holder by turning the knob on the top of the Cruciform Tubing Holder counter clockwise. Do not force the flanged tubing through the hole but be sure to open the Cruciform Tubing Holder sufficiently to allow it to pass.

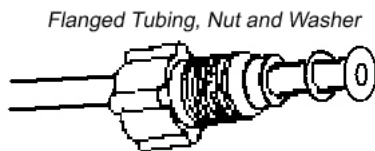

Figure 5

